

200Litre Cabinet for 1 x 18" Driver



The 'Fane Constructor Series' of documents is intended to provide guidance in the construction of loudspeaker cabinets specifically optimised for Fane components. Each enclosure has been designed and rigorously tested to ensure optimum performance from the recommended components. The construction guide and panel cutting lists provide sufficient information to enable any moderately experienced woodworker to build their own enclosures. Alternatively, Fane Acoustics will be pleased to recommend approved cabinet manufacturers. Designs for other enclosures and drive unit combinations are available on request.



Technical Data:

System Components

	Colossus 18B	Colossus 18XB	Crescendo 18B
Low Frequency unit	Colossus 18B	Colossus 18XB	Crescendo 18B
Port Length	108mm	108mm	93mm

Predicted Performance

	Colossus 18B	Colossus 18XB	Crescendo 18B
Frequency Response:	35Hz – 1k5Hz	35Hz – 1kHz	40Hz – 1kHz
Impedance:	8Ω/4Ω/16Ω	8Ω/4Ω/16Ω	8Ω
Average Sensitivity 1W/1M	99dB	98dB	98dB
Power handling (AES)	400watts	600watts	400watts
Maximum Output: Continuous/peak	122/128dB	122/128dB	120/126dB

Compact 200 litre 18" Reflex Enclosure for: Colossus 18B, Colossus 18XB or Crescendo 18B

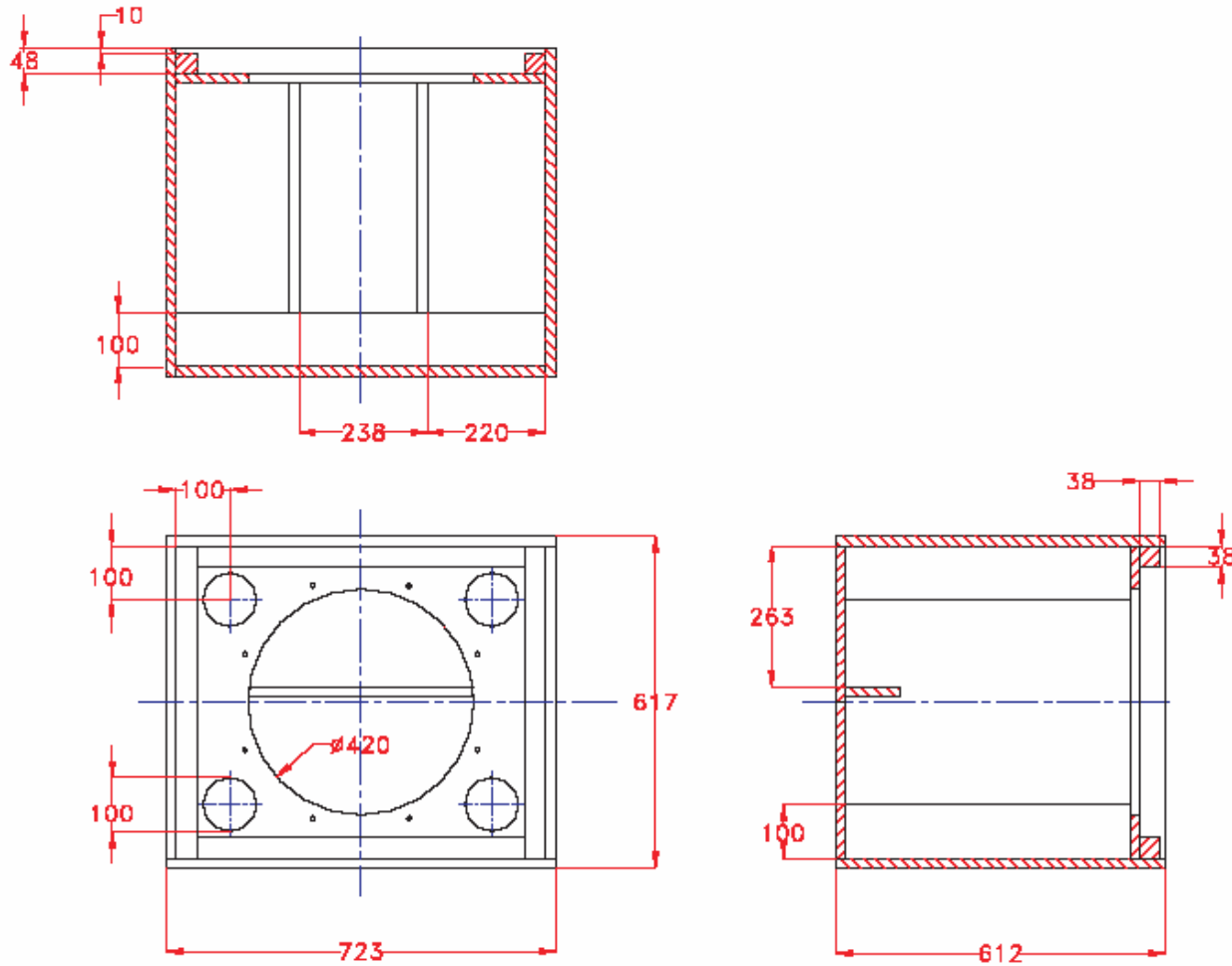

Panel Cutting List

for 18" 200Litre cabinet

18mm Birch ply or MDF

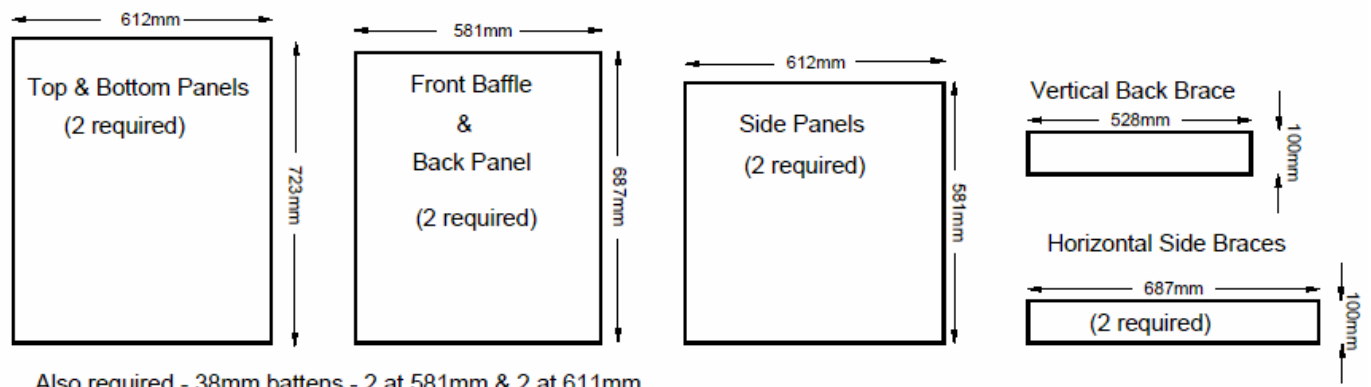

Hints and tips

Choice of timber

We recommend multi-layer 18mm Birch plywood as the best material to withstand the rigours of intensive 'life on the road' or likely exposure to damp conditions. Alternatively, 18mm Medium Density Fibreboard (MDF) offers good acoustic properties with the advantage of being less expensive (although heavier), and may be used where the cabinet will be permanently installed in a dry environment. Both materials accept any type of paint finish extremely well.

Construction technique

All joints should be totally airtight, liberally glued with PVA adhesive and screwed at 200mm (8") centres with 4.2mm or 4.8mm (No.8 or No.10) x 50 mm (2") self-tapping screws. The bracing panels are designed to ensure rigidity of construction, making the cabinet as free as possible from panel resonances caused by the internal forces generated by the loudspeaker drive unit and resulting in unwanted vibration and colouration of the sound. Again, these joints should be glued and screwed using the same method.

Porting

The length of the ports as specified in the drawing should be strictly adhered to. The cut-out size for the port is 100mm (4"). Plastic drainpipe is ideal for this task, but as there could be slight variations in pipe diameter we suggest the cut-out is made after purchasing. The port when fitted should be airtight, which can be achieved by sealing the joint with silicone sealant or polyurethane mastic.

Acoustic insulation

To aid panel damping and prevent internal reflections and standing waves, all internal panels of the cabinet (with the exception of the front baffle) should be lagged with acoustically absorptive material. We recommend the use of acoustic foam wadding, glassfibre insulation or rubber carpet underlay which should be glued, stapled or tacked to the inside of the cabinet, taking care to ensure that port tubes are not obstructed.

Crossover network

This cabinet is designed as a passive unit, and adequate external signal processing arrangements should be made to filter out high-frequency signals.

Internal wiring

Wiring should be kept away from moving loudspeaker parts and fastened to internal panelling to avoid buzzing. We encourage the use of colour coded wiring to identify polarity (red for +ve and black for -ve), and recommend carrying out a phase check before first using the cabinet. This is achieved by applying the positive terminal of a battery to the positive cabinet input which should result in the speaker cone moving forwards if in phase (or by using a dedicated polarity checker).

Drive unit fixing

The drive unit should be front mounted to the baffle using T-nuts and fixing bolts, and is supplied with a length of self adhesive foam sealing strip which should be fitted around the front edge of the speaker cut-outs to guarantee airtight conditions.

Loudspeaker protection

The exposed front of all speaker drive units is of course vulnerable to damage, necessitating some means of protection which must be robust but acoustically transparent. Cloth/foam type grilles are feasible for fixed cabinets, but a metal mesh grille is certainly the preferred and superior option. It is recommended that a foam gasket material is used between the wooden cabinet and the metal grille to prevent any unwanted resonances.

Cabinet hardware

Handles, terminal panels, protective corners, pole mounting accessories etc. are readily available from many different sources.

Fane Acoustics will be pleased to recommend approved suppliers of all associated components.

Cabinet finishing

Cabinet finishing is largely a matter of personal preference and as such, detail of this is omitted from the drawing. Generally cabinets are either painted or covered in carpet or vinyl material. If a carpet material is chosen it is recommended that a very dense tight pile type is used and that metal corner protectors are fitted. Corner protectors will have a defined radius that the edges of the cabinet should be finished to. The cabinet shown on the first page of this document has all the external edges routed with a 13mm radius and coated in a hard wearing textured epoxy paint. Two steel carrying handles have been fitted. There are various types of handles and terminal panels available and again details of these have been omitted. It is recommended that these be purchased and cutouts be made in an appropriate position in the panels before final build. Be aware that handles and terminals are not necessarily airtight, which will be detrimental to performance but can be easily remedied using a silicone sealant or polyurethane mastic to seal all joints.

Warning!

There are safety regulations regarding the installation of loudspeaker systems. This document is intended as a guide to construct a suitable acoustic enclosure for our components. Fane Acoustics can hold no responsibility for the structural integrity of the finished system. The system will be no stronger than the material it is made from and the joinery techniques used to assemble it. Suspending the finished system will require additional hanging hardware. There are companies who specialise in the manufacture and correct use of this hardware. They are experts and must be consulted if overhead suspension of the finished system is intended.